

INSTALLATION, OPERATING & MAINTENANCE MANUAL

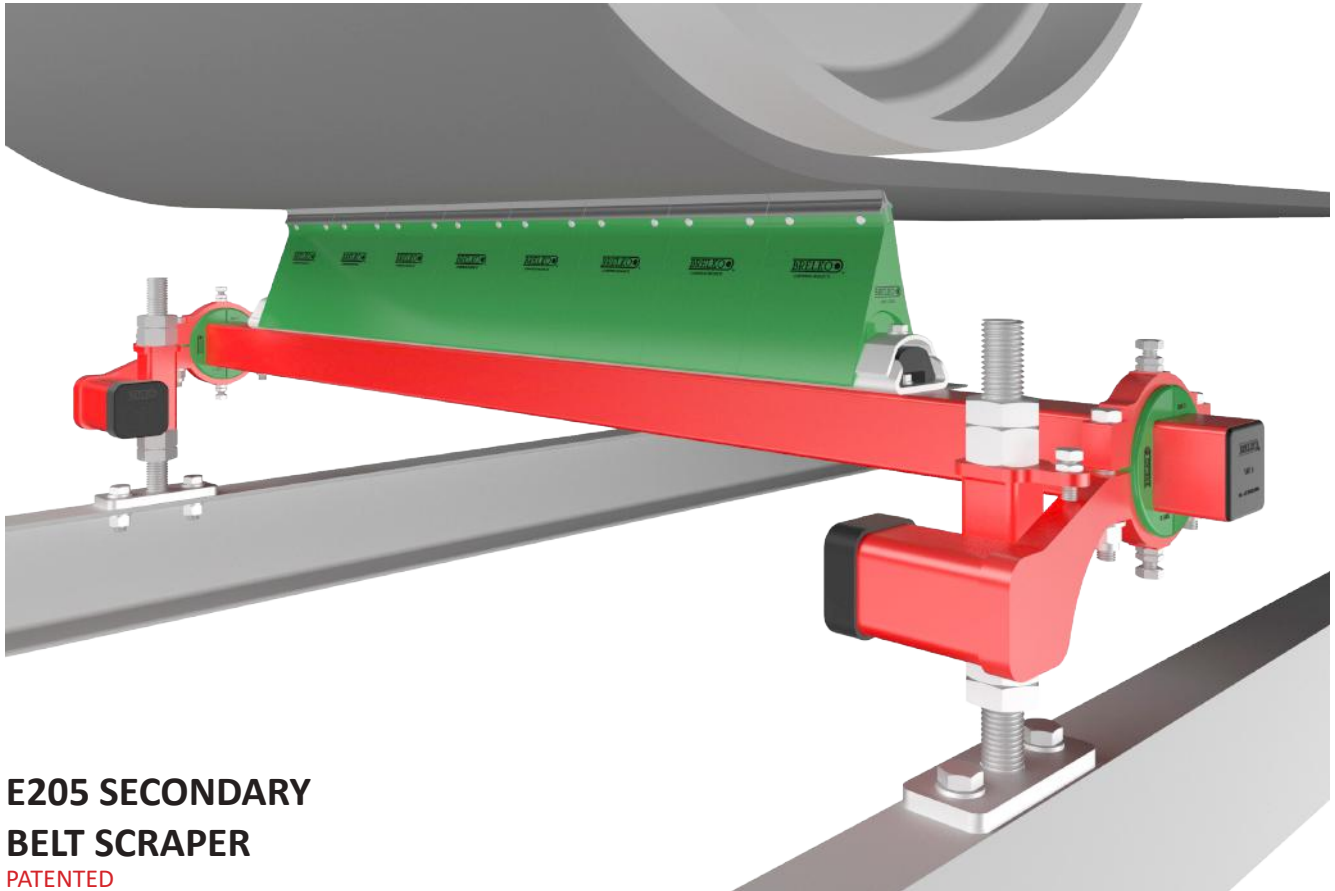

**E205 SECONDARY
 BELT SCRAPER**
 PATENTED

Project Name	:	.
Project Number	:	.
Order Number	:	.
	:	.
Model Number	:	.
Purchase Date	:	.
Purchased From	:	.
Installation Date	:	.
	:	.

Model number information can be found on the Label found on the scraper carton.
 This information will be helpful for any future inquiries or questions about belt scraper replacement parts, specifications or troubleshooting.

Table of Contents

1.	Disclaimer _____	40
2.	Safety Note _____	40
3.	The following symbols may be used in this manual: _____	40
4.	General Information _____	40
4.1.	Application and Features (Standard and Torsion Mount). _____	41
4.2.	Reference Drawing - E205-004 _____	42
5.	Handling _____	43
5.1.	Receiving the goods _____	43
5.2.	Work Safety _____	43
5.3.	Handling _____	44
5.4.	Storage _____	44
5.5.	Preparations for installing Belt Scrapers _____	44
5.6.	Recommended Tools List _____	44
6.	Maintenance _____	45
6.1.	New Installation _____	45
6.2.	Routine Visual Inspection (every 2~4 weeks) _____	45
6.3.	Routine Physical Inspection (every 6~8 weeks) _____	45
6.4.	Parts List and Assembly Instructions (Standard Mount). _____	46
6.5.	Reference Drawing - E205-S-005 _____	47
6.6.	Installation Instructions (Standard Mount) _____	48
6.7.	Reference Drawing - E205-S-006 _____	49
6.8.	Parts List and Assembly Instructions (Torsion Mount). _____	50
6.9.	Reference Drawing - E205-T-007 _____	51
6.10.	Installation Instructions (Torsion Mount). _____	52
6.11.	Reference Drawing - E205-T-008 _____	53
7.	Procedure for Replacing/Repairing Scrapers _____	54
8.	Maintenance Log _____	55
9.	Conveyor Belt & Equipment Check List _____	56
10.	Shipping Specifications _____	59
11.	Trouble Shooting _____	60

1. Disclaimer

Brelko conveyor products (Pty) Ltd hereby disclaims any liability for: damage due to contamination of the material; user's failure to inspect, maintain and take reasonable care of the equipment; injuries or damage resulting from use or application of this product contrary to instructions and specifications contained herein. Brelko's liability shall be limited to repair or replacement of equipment shown to be defective.

2. Safety Note

Observe all safety rules given herein along with owner and Government standards and regulations. Know and understand lockout/tag-out procedures as defined by National Standards Institutes, National Standard for Personnel Protection - Lockout/Tag-out of Energy Sources - Minimum Safety Requirements and Occupational Health and Safety.

3. The following symbols may be used in this manual:



Danger: Immediate hazards that will result in severe personal injury or death.



Warning: Hazards or unsafe practices that could result in personal injury.



Caution: Hazards or unsafe practices that could result in product or property damages.

Important:

Important: Instructions that must be followed to ensure proper installation/operation of equipment.

Note:

Note: General statements to assist the reader.

4. General Information

Brelko belt scrapers are designed to operate with minimum maintenance. However, to maintain superior performance some service is required. When the scraper is installed a regular maintenance program should be set up. This program will ensure that the scraper operates at optimal efficiency and problems can be identified and fixed before the scraper stops working. All safety procedures for inspection of equipment (stationary or operating) must be observed. Secondary Scrapers operate at the discharge end of the conveyor and is in direct contact with the moving belt. Only visual observations can be made while the belt is running. Service tasks can be done only when the conveyor is stopped and by observing the correct lockout/tag-out procedures.

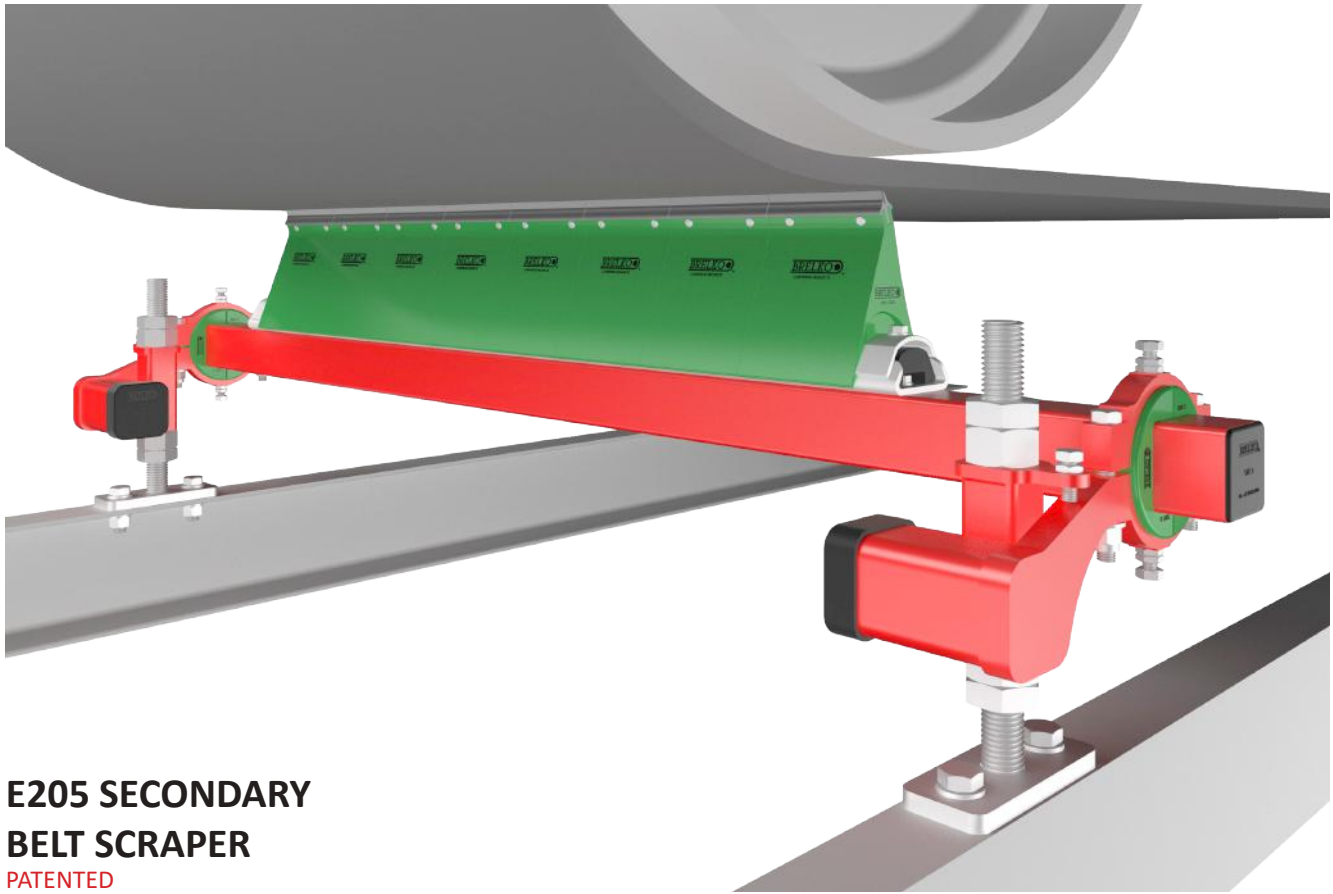

E205 SECONDARY BELT SCRAPER

PATENTED

APPLICATIONS

- Universal choice for all normal cleaning applications.
- Not suitable for mounting directly onto the head pulley.
- Use in conjunction with torsion arm mountings to accommodate different belt thicknesses on the same conveyor and excessive belt movement due to pulley eccentricity, thereby ensuring constant pressure with the belt.
- Selection of correct blade material gives optimum blade life under all operating conditions and conveyed materials.

FEATURES

- Patented V-base torsion holder makes blade changing quick and simple.
- Fully sealed construction of torsion holder prevents material build-up or ingress into the spring unit.
- Twin arm design of the torsion holder prevents radial and lateral blade oscillations and only allows longitudinal blade movement thus ensuring uniform and constant blade contact with the belt, irrespective of variations in belt thicknesses and surface conditions.
- Pre-tensioned blades restrict forward movement and reduces belt contact pressure for optimised cleaning, and extends belt life.
- Lightweight polymeric material used for the torsion holder ensures ease of handling, corrosion protection and minimum impact on belt surface after deflection.
- Patented blade torsion holder and blade design incorporating a deflector skirt ensures accurate assembly and a clean running scraper.
- Brelko self adjusting torsion mountings allow the scraper to maintain a constant pressure on the belt and greatly extends adjustment intervals, also available is the standard adjustable mounting.
- All metal components can be made from corrosion resistant materials.
- Robust construction for longer life.

E205 SINGLE ROW MULTI-BLADE SECONDARY SCRAPER

© 08-2016

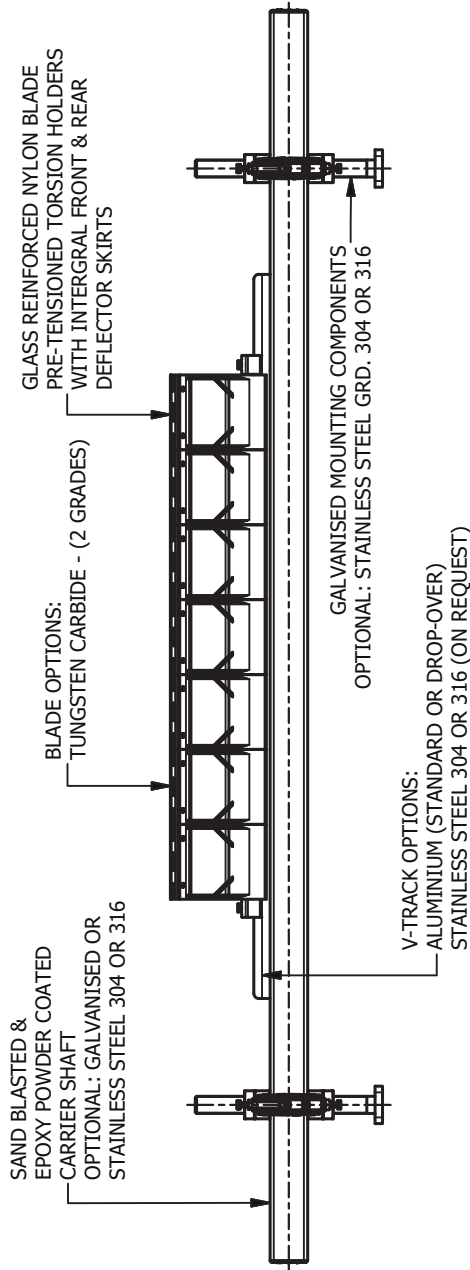

STANDARD CONSTRUCTION & FINISHES FOR BELT WIDTHS FROM

750mm - 1200mm

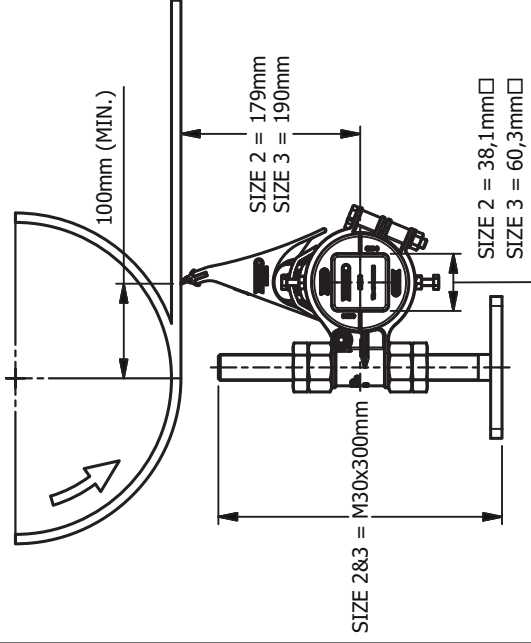
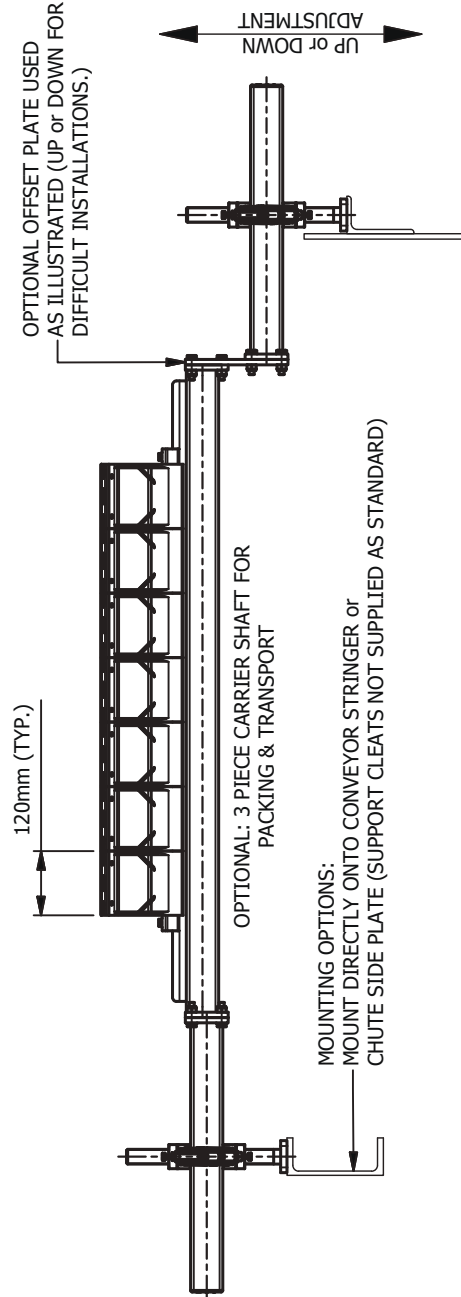

E205-S STANDARD MOUNTING

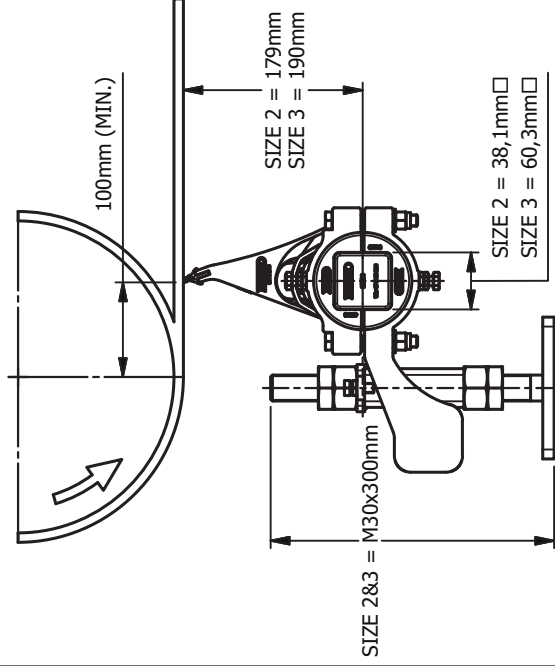

E205-T TORSION MOUNTING

NOTE: FEATURES & OPTIONS SHOWN:
PLEASE REFER TO DETAILED MANUAL FOR INSTALLATION INSTRUCTIONS, MAINTENANCE & SPARE PARTS

DRW. E205-004
No.

REV. 3

5. Handling

5.1. Receiving the goods

Check that the shipment contains all the items specified on the delivery note. If this does not match the delivery note or if the items show any transportation damage, **list it on the freight bill**. Describe the damage and the number of incorrect or faulty items and **contact your supplier immediately**.

Defective parts should not be used under any circumstances. Claims must be made within 8 days from the arrival of goods. Brelko do not cover claims or exchange of product if installation was not carried out according to installation instructions.

5.2. Work Safety

Always use protective gloves and clothing. Always use a lifeline and soft-sole footwear when work will be carried out on raised platforms. Before you move a scraper or plough, check that it is securely attached to the lifting equipment. Always observe local safety regulations.



Before removing/installing equipment, lock out/tag out energy source to conveyor, and/or conveyor accessories.

Turn off and lock out/tag out energy source according to local standards.



If equipment will be installed in an enclosed area, test gas level or duct content before using a cutting torch or welding. Using a cutting torch or welding in an area with gas or dust may cause an explosion.

If using a cutting torch or welding machine, test atmosphere for gas level or dust content.

5.3. Handling

When scrapers are unloaded from the transportation vehicle onto customer’s platform, place them on boards spaced max 1m apart at a minimum of 5cm from the ground.

5.4. Storage

Scrapers can be stored unpacked or in transportation package. Scrapers must not be stored on top of one another, protect the scrapers by storing them in a cool dry area on a flat surface.

5.5. Preparations for installing Belt Scrapers

Before installation, check all measurements and any of the other geometric design

5.6. Recommended Tools List

BELT SCRAPERS	
QTY	DESCRIPTION
2	EXTENSION CORD (20m MINIMUM)
1	PORT-A-PACK (OXY-ACETYLENE)
1	PRICKER
1	COMBINATION GAUGE (WITH SPIRIT LEVEL)
1	STRAIGHT EDGE (1M MINIMUM)
1	90° SET SQUARE
1	5M TAPE MEASURE
2	ADJUSTABLE SPANNERS
1	PIPE WRENCH (3" MINIMUM)
1	SOCKET RATCHET SET (6mm - 30mm)
2	RINGSET SPANNERS - M13, 15, 16, 17, 18, 19, 24
1	STANLEY KNIFE
2	M46 SET SPANNERS
2	M65 SET SPANNERS
1	HARD FACE HAMMER – 4pd
1	SOFT FACE HAMMER - 1KG
3M	NYLON ROPE
2	"G" CLAMPS - 6" - 8"
1	JIMMY LEVER

6. Maintenance

Brelko belt scrapers are designed to operate with minimum maintenance. However, to maintain superior performance some service is required. When the scraper is installed a regular maintenance program should be set up. This program will ensure that the scraper operates at optimal efficiency and problems can be identified and fixed before the scraper stops working. All safety procedures for inspection of equipment (stationary or operating) must be observed. The E205 Secondary Scraper operates at the discharge end of the conveyor and is in direct contact with the moving belt. Only visual observations can be made while the belt is running. Service tasks can be done only with the conveyor stopped and by observing the correct lockout/tag-out procedures.

6.1. New Installation

After the new scraper has run for a few days a visual inspection should be made to ensure the scraper is performing properly. Make adjustments as needed.

6.2. Routine Visual Inspection (every 2~4 weeks)

- A visual inspection of the scraper and belt can determine:
- If the mounts are adjusted at the correct pressure for optimal cleaning
- If the belt looks clean or if there are areas that are dirty
- If the blade is worn out and needs to be replaced
- If there is damage to the blade or other scraper components
- If fugitive material is built up on the scraper or in the transfer area
- If there is cover damage to the belt
- If there is vibration or bouncing of the scraper on the belt
- If a snub pulley is used, a check should be made for material build-up on the pulley
- If any of the above conditions exist, a decision should be made on when the conveyor can be stopped for scraper maintenance.

6.3. Routine Physical Inspection (every 6~8 weeks)

When the conveyor is not in operation and properly locked and tagged out a physical inspection of the scraper to perform the following tasks:

- Clean material build-up off of the scraper blade and pole.
- Closely inspect the blade for wear and any damage. Replace if needed.
- Check blade for proper installation and condition. Replace if needed.
- Ensure full blade to belt contact.
- Inspect the scraper pole for damage.
- Inspect all fasteners for tightness and wear. Tighten or replace as needed.
- Replace any worn or damaged components.
- Check the pressure of the scraper blade on the belt. Adjust the pressure if necessary, refer to scraper model installation guide.

When maintenance tasks are completed, test run the conveyor to ensure the scraper is performing properly.

PARTS LIST - REF. DRW. No.: E205-S-005

ITEM No.	DESCRIPTION	SIZE	SHAFT LENGTH (mm)	BELT WIDTH (mm)	PART No.
A.	Carrier Assembly Including shaft, "V" track, end stops and end caps.	Size 2	1500	750	2-8.1.2
		Size 3	2000	900-1200	2-8.1.3
D.	Optional / 3-Piece Shaft Assembly including inner carrier shaft, outer carrier shafts end stops and off-set plates.	Size 2	1500	750	2-8.1.2-3P
		Size 3	2000	900-1200	2-8.1.3-3P
E.	Standard Mount Assembly- Including clamp piece, nylon bushes, bolts, nuts and washers. Note: - Spindle to be ordered separately.	Size 2	N/A	750	2-3.2
		Size 3	N/A	900-1200	2-3.3
G.	Spindle Assembly – including lock nuts.	Size 2&3	N/A	750-1200	2-1.3
H.	Torsion Holder Assembly c/w :-				
	Chrome Tool Steel blade -C10	120mm	N/A	750-1200	2-5.63
	Tungsten Carbide blade -TC	120mm	N/A	750-1200	2-5.61
	Triplex Tungsten blade (2mm) -T3	120mm	N/A	750-1200	2-5.62
J.	Torsion Holder	120mm	N/A	750-1200	2-5.45
K.	Blade Holder c/w :-				
	Chrome Tool Steel blade -C10	120mm	N/A	750-1200	2-6.07
	Tungsten Carbide blade -TC	120mm	N/A	750-1200	2-6.05
	Triplex Tungsten blade (2mm) -T3	120mm	N/A	750-1200	2-6.06

NOTE! Always quote belt width.

ASSEMBLY INSTRUCTIONS

- All scrapers will be wrapped and clearly marked with the model number, scraper blade grade and belt width.
 - Note: - Scrapers will be supplied with all nuts and bolts to complete the assembly and installation.
- Referring to the parts list and installation data sheet check that the correct parts and quantities have been supplied for the model and belt width of scraper ordered.
- Normally scrapers are supplied with blades (3), torsion holders (4) and end stops (5) assembled on the carrier shaft (1). If not, assemble as shown using a lithium base grease as a lubricant to ease future removal of blades. If necessary, use a rubber mallet to tap the blades into the "V" track. Do not over-tighten end stop (5) set screws.
- Check that the blades (3) are free to deflect forwards and backwards. If any blades foul those adjacent, slightly slacken end stop (5) set screws, and tap the torsion holders (4) sideways until the blades (3) clear each other. Tighten end stop (5) set screws.
 - Note: - There should be 0,5mm gap between blades (3).
- Depending on the installation access (see Installation Guide paragraph-1) an optional three piece shaft may be required, then one or both of the carrier shaft end pieces may now be attached.
 - Note: - Three piece carrier shafts are not supplied as standard and must be ordered separately.
- Check whether the optional offset plates (10) are to be used, and if so; ensure that they are correctly assembled. Ensure that all nuts and bolts are firmly fastened.
 - Note: - Offset plates (10) are not supplied as standard and must be ordered separately.
- Proceed with the installation as per the installation guide.

All technical and dimensional information subject to change. All general Terms and Conditions of sale, including limitations of our liability, apply to all products and services sold.

E205S STANDARD MOUNT SINGLE ROW MULTI-BLADE SECONDARY SCRAPER

© 08-2016

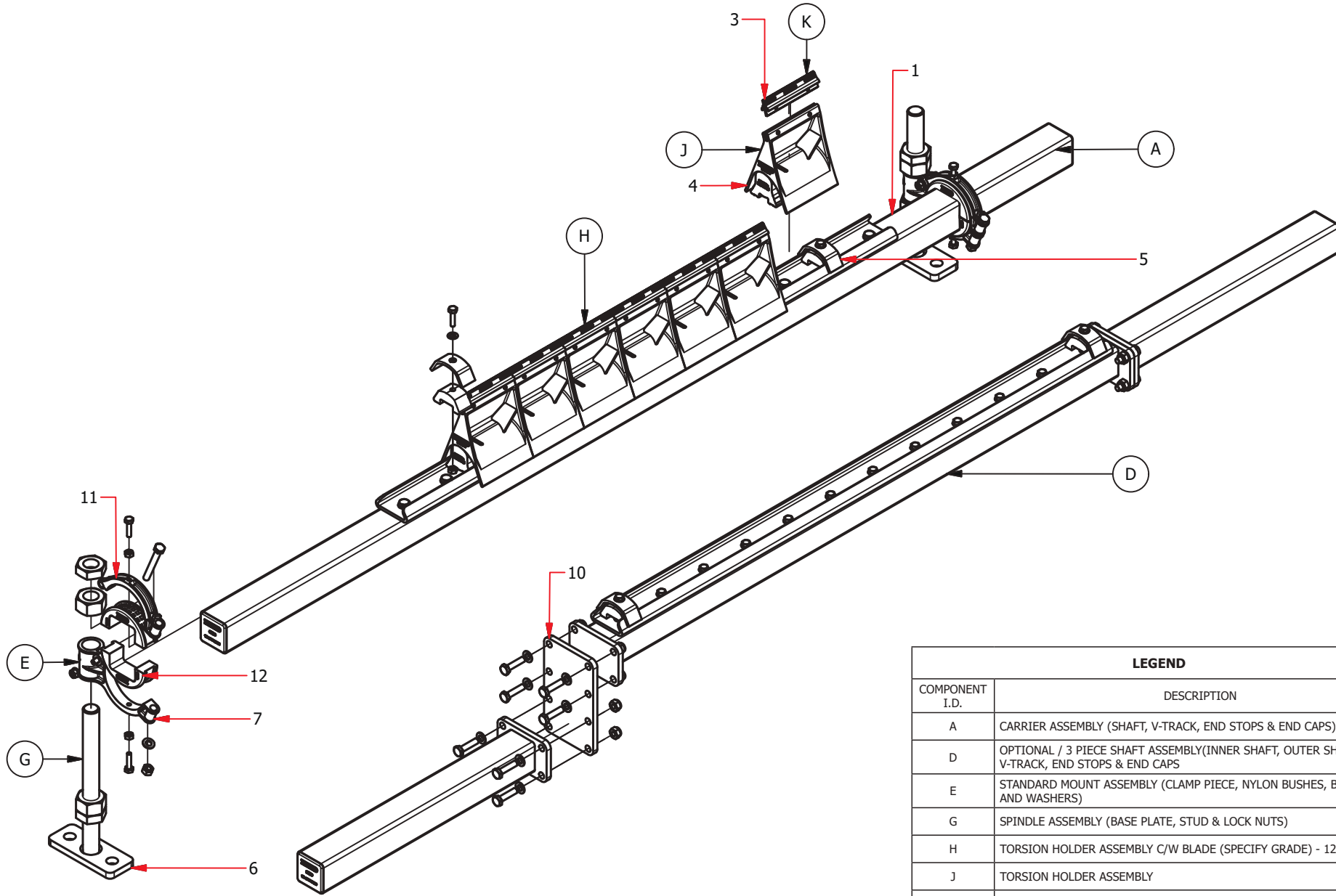

LEGEND	
COMPONENT I.D.	DESCRIPTION
A	CARRIER ASSEMBLY (SHAFT, V-TRACK, END STOPS & END CAPS)
D	OPTIONAL / 3 PIECE SHAFT ASSEMBLY(INNER SHAFT, OUTER SHAFT, V-TRACK, END STOPS & END CAPS)
E	STANDARD MOUNT ASSEMBLY (CLAMP PIECE, NYLON BUSHES, BOLTS, NUTS AND WASHERS)
G	SPINDLE ASSEMBLY (BASE PLATE, STUD & LOCK NUTS)
H	TORSION HOLDER ASSEMBLY C/W BLADE (SPECIFY GRADE) - 120MM
J	TORSION HOLDER ASSEMBLY
K	CAST BLADE HOLDER C/W BLADE (SPECIFY GRADE) - 120MM

PARTS LIST: FOR STANDARD MOUNT

PLEASE SPECIFY BELT WIDTH WHEN ORDERING

DRW. No. E205-S-005

REV. 1

INSTALLATION GUIDE - REF. DRW. No.: E205-S-006

1. Refer to the Assembly Instructions, Parts List and the Parts List Drawing to confirm that all the necessary parts have been supplied and that the scraper is correctly assembled. Depending on access space, it may be necessary to use an optional 3-piece carrier. Then one or both of the carrier shaft end pieces can be fitted once the scraper is in position.
2. Remove the standard mount clamp piece (11), and green nylon bushes (12) from the standard mounts (7).
3. Check that the lock nuts move freely on the spindles.
4. Remove the standard mount (7) from the spindles (6).
5. Referring to the dimensions given in the table, see the Installation drawing, select the optimum position for the scraper and mark the location of the access apertures.
6. With reference to the Installation drawing, select the most convenient location for the mounting spindles. There are four possible positions but in all cases ensure that the spindles remains at $90^\circ (\pm 10^\circ)$ to the belt surface. If no suitable location can be found to attach the spindle foot to the conveyer structure, the 3 piece shafts may be used as shown in the Parts List Drawing.
 - *Note:* - Offset plates (10) and 3-piece shafts are not supplied as standard, and must be ordered separately.
7. Fix the spindles (6) firmly in position. Locate standard mount (7) on spindles as shown.
8. Check that carrier shaft end pieces and carrier shaft centrepiece are firmly bolted together (3-piece shaft only).
9. Position carrier shaft underneath the conveyor belt centrally with reference to belt edges and head pulley.
10. Position carrier shaft and attached clamp piece (11) and bushes (12) on standard mount (7) as shown and fit bolts, washers and nuts. Tighten finger tight.
 - *Note:* - It may be necessary to adjust the location of the mount on the spindles by means of spindles nuts so that the blades are clear of the belt surface.
11. Lay a straight edge on the top face of the carrier shaft end piece and rotate the assembled carrier shaft until the straight edge is parallel to the belt surface.
 - *Note:* - This step must be done carefully to ensure that the angle of the blade's to the belt is correct.
12. Tighten bolts and nuts. Do not over tighten!
13. By means of spindle nuts adjust the scraper towards the belt surface until all the blades contact the belt surface.
14. Adjust the scraper half a turn of the spindle nuts towards the belt.
15. Check that all nuts and bolts are firmly fastened.
16. Check that the spindle lock nuts are firmly tightened.
17. Start the conveyor and check if all blades are moving freely and scraping in full contact with the belt surface. If further adjustment is required, stop the conveyor and adjust the scraper half a turn of the spindle nuts towards the belt until all blades are scraping satisfactory.
 - *Note:* - Do not over adjust the scraper.
18. Check that the spindle lock nuts are firmly tightened.
19. To ensure future adjustment of the spindle nuts wrap thread with protective cloth, to protect the thread against corrosion, rust and ingress of dust.
20. It may be necessary to install stabilising rollers to keep the belt surface flat and stop belt bounce.

E205S STANDARD MOUNT SINGLE ROW MULTI-BLADE SECONDARY SCRAPER

© 08-2016

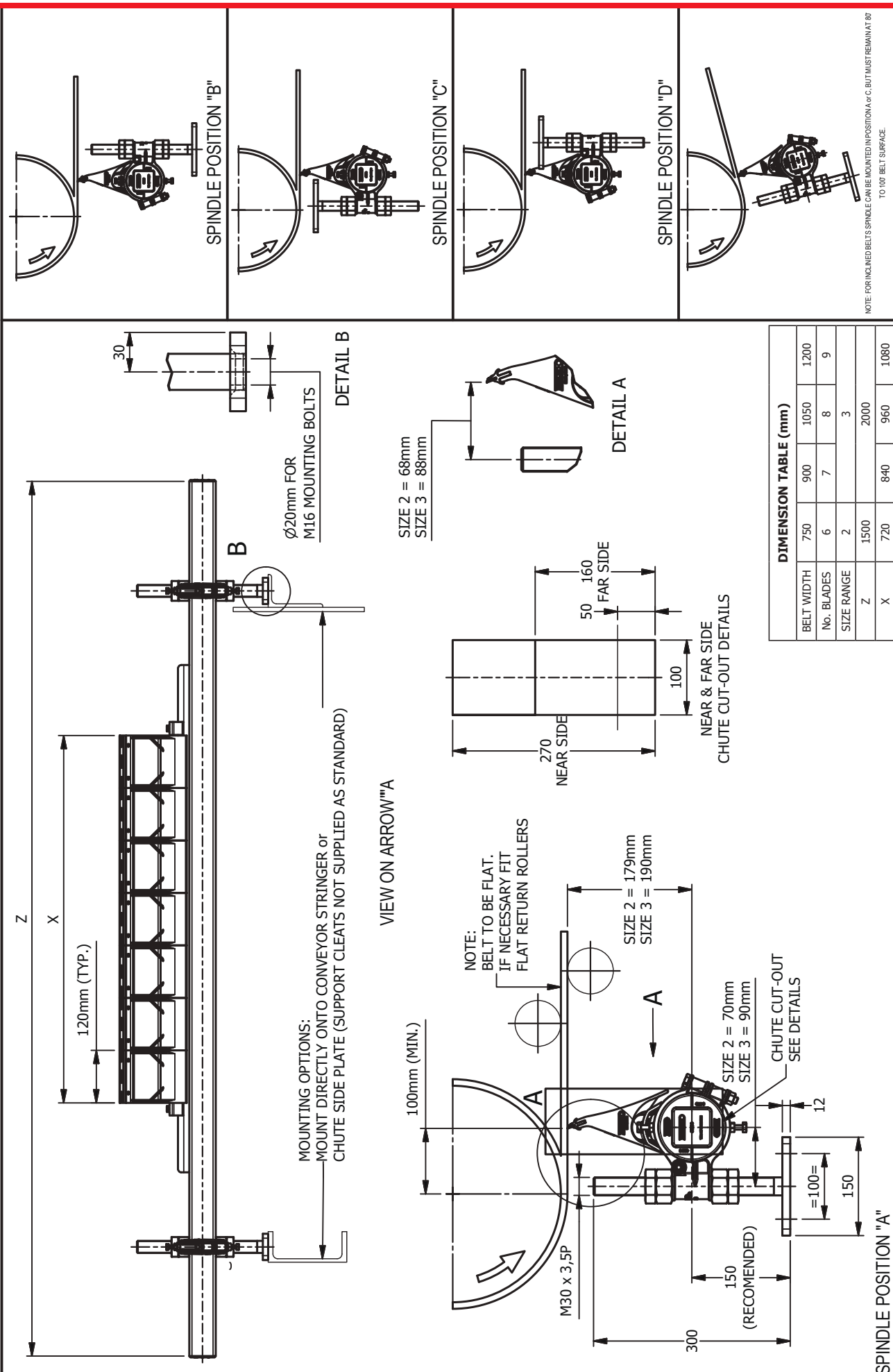

INSTALLATION DETAIL: STANDARD MOUNT.

ALWAYS SPECIFY BELT WIDTH WHEN ORDERING

DRW. E205-S-006
REV. 3

PARTS LIST - REF. DRW. No.: E205-T-007

ITEM No.	DESCRIPTION	SIZE	SHAFT LENGTH (mm)	BELT WIDTH (mm)	PART No.
A.	Carrier Assembly Including shaft, "V" track and end stops.	Size 2	1500	750	2-8.1.2
		Size 3	2000	900-1200	2-8.1.3
D.	Optional / 3-Piece Shaft Assembly including inner carrier shaft, outer carrier shafts end stops and off-set plates.	Size 2	1500	750	2-8.1.2-3P
		Size 3	2000	900-1200	2-8.1.3-3P
F.	Torsion Mount Assembly – Including clamp piece, nylon bushes, bolts, nuts and washers. Note: - Spindle to be ordered separately.	Size 2	N/A	750	2-2.2
		Size 3	N/A	900-1200	2-2.3
G.	Spindle Assembly – including lock nuts.	Size 2&3	N/A	750-1200	2-1.3
H.	Torsion Holder Assembly c/w :-				
	Chrome Tool Steel blade -C10	120mm	N/A	750-1200	2-5.63
	Tungsten Carbide blade -TC	120mm	N/A	750-1200	2-5.61
	Triplex Tungsten blade (2mm) -T3	120mm	N/A	750-1200	2-5.62
J.	Torsion Holder	120mm	N/A	750-1200	2-5.45
K.	Blade Holder c/w :-				
	Chrome Tool Steel blade -C10	120mm	N/A	750-1200	2-6.07
	Tungsten Carbide blade -TC	120mm	N/A	750-1200	2-6.05
	Triplex Tungsten blade (2mm) -T3	120mm	N/A	750-1200	2-6.06

NOTE! Always quote belt width.

ASSEMBLY INSTRUCTIONS

- All scrapers will be wrapped and clearly marked with the model number, scraper blade grade and belt width.
 - Note: - Scrapers will be supplied with all nuts and bolts to complete the assembly and installation.
- Referring to the parts list and installation data sheet check that the correct parts and quantities have been supplied for the model and belt width of scraper ordered.
- Normally scrapers are supplied with blades (3), torsion holders (4) and end stops (5) assembled on the carrier shaft (1). If not, assemble as shown using a lithium base grease as a lubricant to ease future removal of blades. If necessary, use a rubber mallet to tap the blades into the "V" track. Do not over-tighten end stop (5) set screws.
- Check that the blades (3) are free to deflect forwards and backwards. If any blades foul those adjacent, slightly slacken end stop (5) set screws, and tap the torsion holders (4) sideways until the blades (3) clear each other. Tighten end stop (5) set screws.
 - Note: - There should be 0,5mm gap between blades (3).
- Depending on the installation access (see Installation Guide paragraph-1) an optional three piece shaft may be required, then one or both of the carrier shaft end pieces may now be attached.
 - Note: - Three piece carrier shafts are not supplied as standard and must be ordered separately.
- Check whether the optional offset plates (10) are to be used, and if so; ensure that they are correctly assembled. Ensure that all nuts and bolts are firmly fastened.
 - Note: - Offset plates (10) are not supplied as standard and must be ordered separately.
- Proceed with the installation as per the installation guide.

All technical and dimensional information subject to change. All general Terms and Conditions of sale, including limitations of our liability, apply to all products and services sold.

E205T TORSION MOUNT SINGLE ROW MULTI-BLADE SECONDARY SCRAPER

© 08-2016

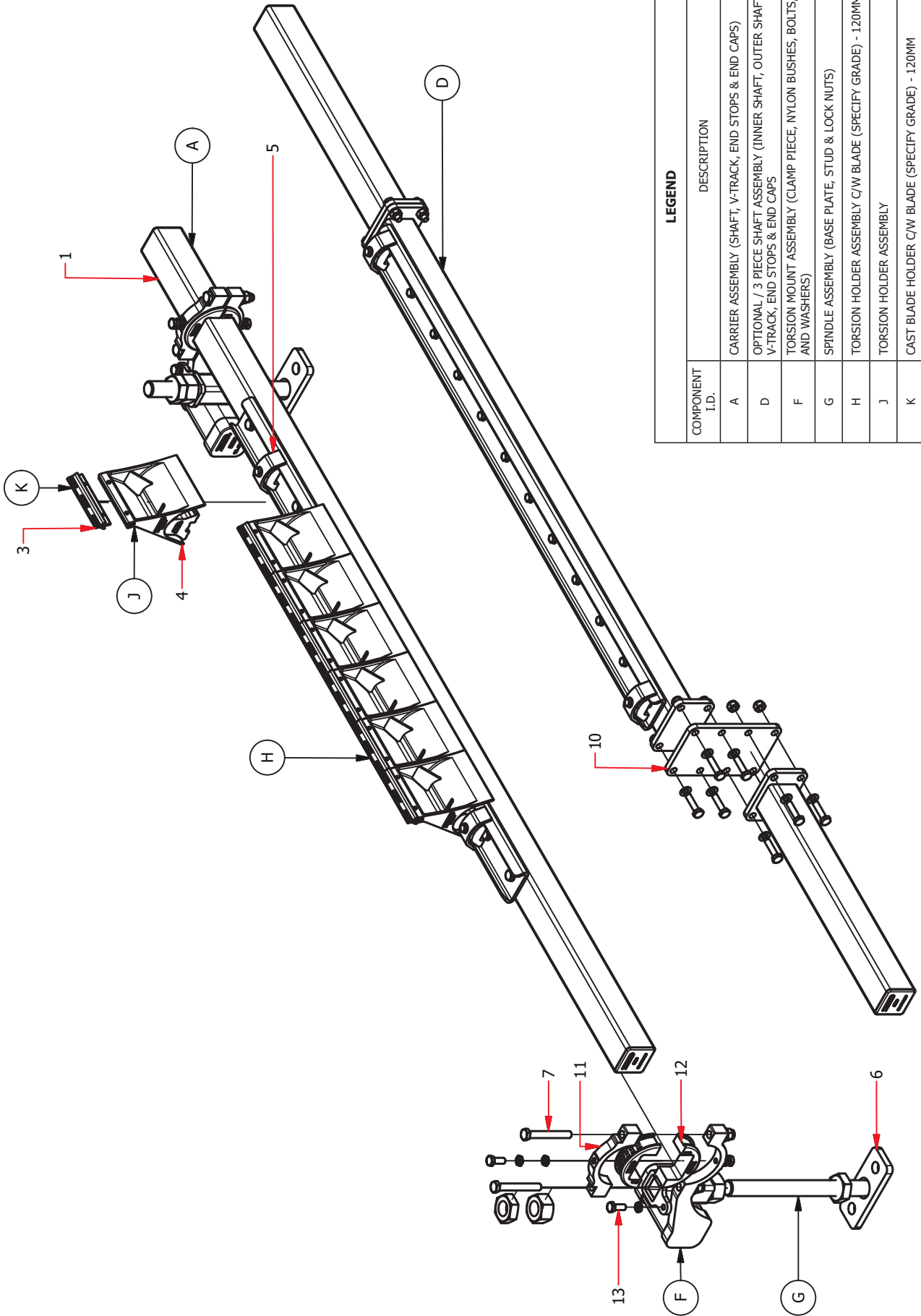

COMPONENT I.D.	DESCRIPTION
A	CARRIER ASSEMBLY (SHAFT, V-TRACK, END STOPS & END CAPS)
D	OPTIONAL / 3 PIECE SHAFT ASSEMBLY (INNER SHAFT, OUTER SHAFT, V-TRACK, END STOPS & END CAPS)
F	TORSION MOUNT ASSEMBLY (CLAMP PIECE, NYLON BUSHES, BOLTS, NUTS AND WASHERS)
G	SPINDLE ASSEMBLY (BASE PLATE, STUD & LOCK NUTS)
H	TORSION HOLDER ASSEMBLY C/W BLADE (SPECIFY GRADE) - 120MM
J	TORSION HOLDER ASSEMBLY
K	CAST BLADE HOLDER C/W BLADE (SPECIFY GRADE) - 120MM

PARTS LIST: FOR TORSION MOUNT

PLEASE SPECIFY BELT WIDTH WHEN ORDERING

DRW. E205-T-007
No.

REV. 2

INSTALLATION GUIDE - REF. DRW. No.: E205-T-008

1. Refer to the Assembly Instructions, Parts List and the Parts List Drawing to confirm that all the necessary parts have been supplied and that the scraper is correctly assembled. Depending on access space, it may be necessary to use an optional 3-piece carrier. Then one or both of the carrier shaft end pieces can be fitted once the scraper is in position.
2. Remove the torsion mount clamp piece (11), and green nylon bushes (12) from torsion mounts (8).
3. Check that the lock nuts move freely on the spindles.
4. Remove the torsion mount (8) from the spindles (6).
5. Referring to the dimensions given in the table, see the Installation drawing, select the optimum position for the scraper and mark the location of the access apertures.
6. With reference to the Installation drawing, select the most convenient location for the mounting spindles. There are two possible positions but in all cases ensure that the spindles remains at $90^\circ (\pm 10^\circ)$ to the belt surface. If no suitable location can be found to attach the spindle foot to the conveyer structure, the 3 piece shafts may be used as shown in the Parts List Drawing.
 - *Note:* - Offset plates (10) and 3-piece shafts are not supplied as standard, and must be ordered separately.
7. Fix the spindles (6) firmly in position. Locate torsion mount (8) on spindles as shown.
8. Check that carrier shaft end pieces and carrier shaft centrepiece are firmly bolted together (3-piece shaft only).
9. Position carrier shaft underneath the conveyor belt centrally with reference to belt edges and head pulley.
10. Position carrier shaft and attached clamp piece (11) and bushes (12) on torsion mount (8) as shown and fit bolts, washers and nuts. Tighten finger tight. Adjust set screws (13) until they just touch the torsion arm. Pre-tension the torsion mount and tighten set screws (13) one full turn.
 - *Note:* - It may be necessary to adjust the location of the mount on the spindles by means of spindles nuts so that the blades are clear of the belt surface.
11. Lay a straight edge on the top face of the carrier shaft end piece and rotate the assembled carrier shaft until the straight edge is parallel to the belt surface.
 - *Note:* - This step must be done carefully to ensure that the angle of the blades to the belt is correct.
12. Tighten bolts and nuts. Do not over tighten!
13. By means of spindle nuts adjust the scraper towards the belt surface until all the blades contact the belt surface.
14. Adjust the scraper half a turn of the spindle nuts towards the belt.
15. The blades should now rest on the belt surface.
 - *Note:* - Check that the set screws (13) are not touching the torsion arm. If they are still in contact with the arm continue to adjust the scraper towards the belt in increments of half a turn of the lock nuts until the set screw (13) just clears the torsion arm.
16. Slacken the set screws (13) four full turns and tighten the lock nuts.
17. Check that the complete scraper assembly can move freely up and down on the torsion mounts, and that all blades can move freely.
18. Check that all nuts and bolts are firmly fastened.
19. Check that the spindle lock nuts are firmly tightened.
20. Start the conveyor and check if all blades are moving freely and scraping in full contact with the belt surface. If further adjustment is required, stop the conveyor and adjust the scraper half a turn of the spindle nuts towards the belt until all blades are scraping satisfactory.
 - *Note:* - Do not over adjust the scraper.
21. Check that the spindle lock nuts are firmly tightened.
22. To ensure future adjustment of the spindle nuts wrap thread with protective cloth, to protect the thread against corrosion, rust and ingress of dust.
23. It may be necessary to install stabilising rollers to keep the belt surface flat and stop belt bounce.

E205T TORSION MOUNT SINGLE ROW MULTI-BLADE SECONDARY SCRAPER

© 08-2016

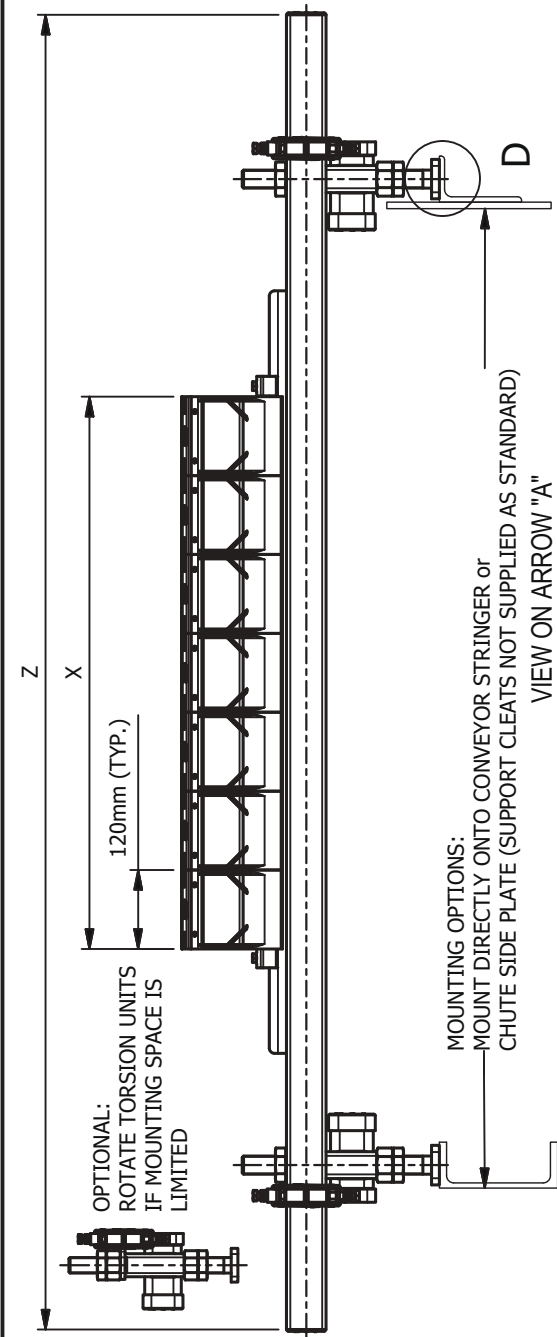
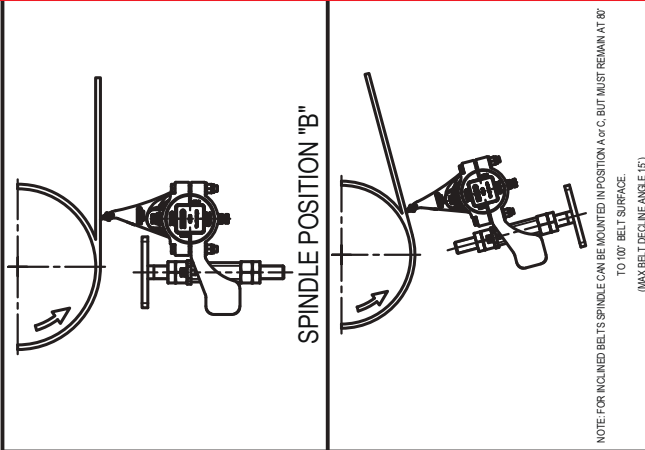

NOTE:
BELT TO BE FLAT.
IF NECESSARY FIT
FLAT RETURN ROLLERS

100mm (MIN.)

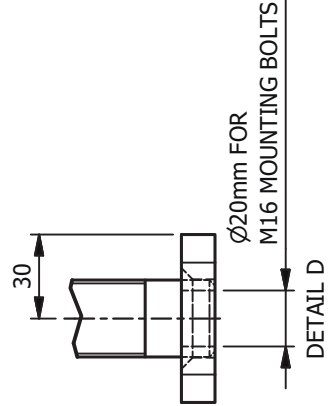
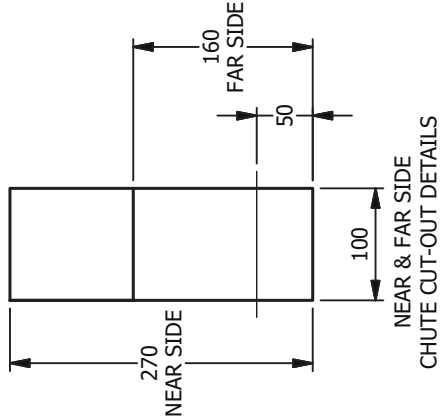
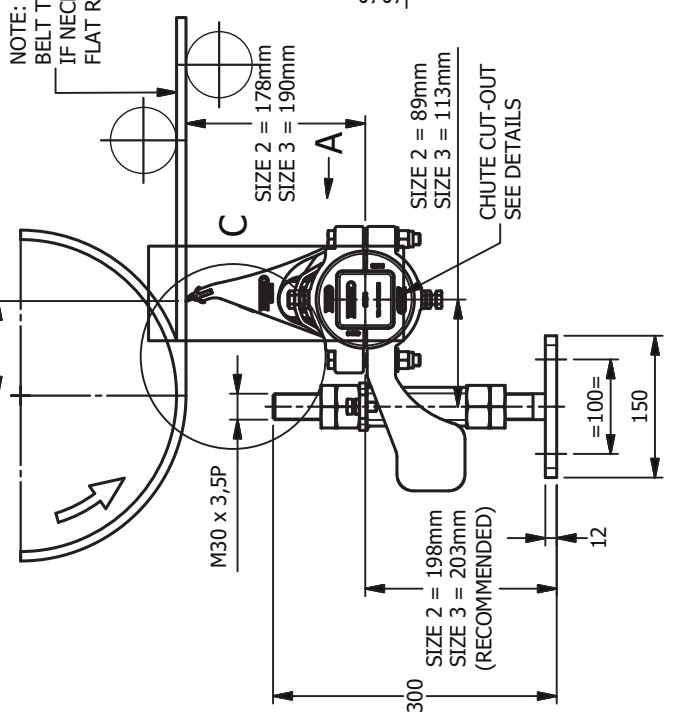

DIMENSION TABLE (mm)					
BELT WIDTH	750	900	1050	1200	
No. BLADES	6	7	8	9	
SIZE RANGE	2	3			
Z	1500				2000
X	720	840	960	1080	

DETAIL C

SPINDLE POSITION "A"

INSTALLATION DETAIL: STANDARD MOUNT. ALWAYS SPECIFY BELT WIDTH WHEN ORDERING. DRW. E205-T-008 No. REV. 3

7. Procedure for Replacing/Repairing Scrapers

Repair/replace Belt Scraper components when, general maintenance tasks are performed scraper damage due to accelerated blade wear, scraper damage due to blocked chutes, clip joints/emergency belt repairs etc.

- 7.1. Request permit to work from an authorised person, who will isolate and lock out the belt.
- 7.2. Open access door, if provided, and clear loose items about the spindle before commencing with work.
- 7.3. Loosen the locknuts and then lower/raise the scrapers, as necessary.
- 7.4. If replacing scrapers, insert balance pipe – which must be longer than the carrier shaft – into the one end of the shaft.
- 7.5. Loosen the shaft and turn it 180 degrees, that is, scraper tips pointing downward.
- 7.6. Remove one spindle on the intended exit end.
- 7.7. Slide out the scraper assembly from the intended exit end of the pipe.
- 7.8. Service the scraper on the platform.
- 7.9. Blade replacement:

Refer to Brelko installation instructions for belt scraper model in use.

Brelko nylon torsion holders have been designed to break out of the torsion holder support v-track to protect the scraper, scraper mounting components, conveyor belt and conveyor belt equipment against damage due to emergency clip joints, loose/damaged splicing, belt protrusions, chute blockages etc. If torsion holders damaged occur follow the steps below to replace individual or all of the torsion holders:

- a. Remove and clean the damaged scraper to assess the amount of damage to the scraper, the scraper torsion holders and scraper components.
 - b. If the scraper has been working for more than 4 weeks and/or there has been significant blade wear remove and replace all the torsion holders and blades and replace with new kits, this will eliminate belt damage due to uneven scraper torsion holder and blades.
 - c. If the scraper has been working for 1~2 weeks replace only damaged torsion holders and blades, however assess the damage and ensure the remaining torsion holders will not cause any damage to the conveyor belt.
- 7.10. Scraper Adjustment:
- ### **Refer to Brelko installation instructions for belt scraper model in use.**
- a. Reposition using the balance pipe.
 - b. Obtain sanction for test, or permission to adjust for performance evaluation.
 - c. Tighten all nuts and ensure that belt cleaning or scraper performance is acceptable.
 - d. Clear up any loose items which resulted from your work.



CUSTOMER: _____

CODE: [] [] [] [] [] [] [] [] [] []

ATTENTION: _____

CONTACT TEL: _____

DATE IN: _____

No: 25853

CONTRACT/ORDER No.: _____

CONTRACT/ORDER No.: _____

JOB CARD SERVICE WAYBILL

BELT No.	BELT SIZE	EQUIPMENT TYPE	MOUNT TYPE	EQUIPMENT CONDITION (AVERAGE/GOOD/EXCELLENT)	INSPECTION FINDINGS		WORK DONE or ACTION RECOMMENDED							IMPORTANT NOTES / COMMENTS								
					BELT SCRAPER / PRODUCT	CONVEYOR BELT and CHUTE	SPARES FITTED			MINE SPARES = M / BRELKO SPARES = B												
				PRODUCT LIFE REMAINING (LOW / MEDIUM / HIGH)	CLEANING (POOR / AVERAGE / EXCELLENT)	NEW / EVEN	GROOVES / WORN	PROTRUSIONS (CLIPS / SPACED / LOOSE PATCH)	EXCESSIVE	AVERAGE	LITTLE	BLADES / HOLDERS	MOUNTS	CARRIER ASSEMBLY	SPINDLES	SKIRTING	OTHER SPARES	ADJUST SCRAPER SET	TIGHTEN LOOSE NUTS & BOLTS	FURTHER INVESTIGATION	CLEANED	

ALWAYS REFER THE ABOVE COMMENTS TELEPHONICALLY TO THE RELEVANT PERSON FOR SPELLING REFER TO THE GENERAL AND CONVEYING TERMS SHEET INCLUDED IN THE INDEX SECTION OF THIS WAYBILL BOOK.

CUSTOMER REPRESENTATIVE: _____ TIME IN: _____

CUSTOMERS SIGNATURE: _____ (please print) TIME OUT: _____

BRELKO REPRESENTATIVE: _____

SAFETY: _____



DOC NO	ISSUE NO	REVISION	SEPTEMBER	PAGE
15/07	9	9	2016	1 of 2

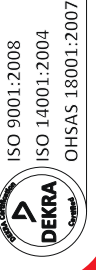

CONVEYOR BELT & EQUIPMENT CHECK LIST / QCP

CUSTOMER DETAILS

Customer Name:	Contact Number:
Attention:	Date of Inspection
Inspected By	Brelko Representative

CONVEYOR DIMENSIONS

Belt Number:	Material Carried:	Belt Speed:	
Belt Length:	Belt Width:	Troughing Angle:	
Top Cover Condition:		Bottom Cover Condition:	
Splice:	Yes <input type="checkbox"/> No <input type="checkbox"/>	Clip Joint:	Yes <input type="checkbox"/> No <input type="checkbox"/>
Conveyor Running	Yes <input type="checkbox"/> No <input type="checkbox"/>	Inspection Tags:	Yes <input type="checkbox"/> No <input type="checkbox"/>
Edge Damage:	Yes <input type="checkbox"/> No <input type="checkbox"/>	Cover Strip:	Yes <input type="checkbox"/> No <input type="checkbox"/>
Comments:			

HEAD END / HEAD CHUTE

Chute Condition:	Head Pulley Lagging:
Snub Pulley Lagging:	Build up:
Belt Movement:	
Comments:	

IDLER CHECK

Trough Idler Condition:	Return Idler Condition:
Troughing Frame Condition:	Return Frame Condition:
Comments:	

PRIMARY SCRAPER

Position Correct:	Yes <input type="checkbox"/> No <input type="checkbox"/>	Type of Primary Scraper installed:	
<small>(Contact of Scraper Blade must be between 10 to 30 degrees, under the pulley horizontal line.)</small>			
Mounts firmly mounted:	Yes <input type="checkbox"/> No <input type="checkbox"/>	All bolts, nuts tightened:	Yes <input type="checkbox"/> No <input type="checkbox"/>
Adequate Tensioning:	Yes <input type="checkbox"/> No <input type="checkbox"/>	All Caps, Denso Tape in place:	Yes <input type="checkbox"/> No <input type="checkbox"/>
Housekeeping:			
Chute Material build up:			
Blade Wear:	Low <input type="checkbox"/> Medium <input type="checkbox"/> High <input type="checkbox"/>	Cleaning:	Poor <input type="checkbox"/> Fair <input type="checkbox"/> Good <input type="checkbox"/>
Comments:			

SECONDARY SCRAPER #1

Type / Model of Secondary Scraper Installed:			
Positioning Correct: <input type="checkbox"/>			
<small>(Scraper blade must preferably be a minimum 100mm from pulley tangent.)</small>			
All Caps, Denso Tape in Place:	Yes <input type="checkbox"/> No <input type="checkbox"/>	Mounts firmly mounted:	Yes <input type="checkbox"/> No <input type="checkbox"/>
All Bolts & Nuts Tightened:	Yes <input type="checkbox"/> No <input type="checkbox"/>	Adequate tension/adjustment:	Yes <input type="checkbox"/> No <input type="checkbox"/>
Angle Correct Set:	Yes <input type="checkbox"/> No <input type="checkbox"/>	Carrier Frame cut to size	Yes <input type="checkbox"/> No <input type="checkbox"/>
<small>Angle of scraper must be 90 degrees to the conveyor belt, dependant on conditions.</small>			
Chute / Material build up:	Yes <input type="checkbox"/> No <input type="checkbox"/>	Housekeeping:	
Blade wear:	Low <input type="checkbox"/> Medium <input type="checkbox"/> High <input type="checkbox"/>	Cleaning:	Poor <input type="checkbox"/> Fair <input type="checkbox"/> Good <input type="checkbox"/>
Comments:			



DOC No	ISSUE No	REVISION	OCTOBER	PAGE
FS 023	04	04	2018	Page 1 of 3



SECONDARY SCRAPER #2

Type / Model of Secondary Scraper Installed:																
Positioning Correct:																
Scraper blade must preferably be a minimum 100mm from pulley tangent.																
All Caps, Denso Tape in Place:			Yes		No		Mounts firmly mounted:			Yes		No				
All Bolts & Nuts Tightened:			Yes		No		Adequate tension/adjustment:			Yes		No				
Angle Correct Set:			Yes		No		Carrier Frame cut to size			Yes		No				
Angle of scraper must be 90 degrees to the conveyor belt, dependant on conditions.																
Chute / Material build up:			Yes		No		Housekeeping:									
Blade wear:			Low		Medium		High		Cleaning:		Poor		Fair		Good	
Comments:																

TAKE UP PULLEYS / COUNTERWEIGHT / PLOUGH

Type / Model of Plough Installed:													
Are Flat Return Idlers Installed:		(In front)		Yes		No		(Behind)		Yes		No	
Any excessive belt movement:		Yes		No		Adequate space for material to fall off of conveyor belt				Yes		No	
Is the Plough firmly mounted:		Yes		No		Is the Safety Chain firmly mounted and correctly adjusted:				Yes		No	
Is the Plough Free moving:		Yes		No		Is the entire Blade / Nose Piece in contact with the conveyor belt:				Yes		No	
Housekeeping:													
Comments:													

CONVEYOR BELT TRACKING / ALIGNMENT

Is the Belt Tracking centre:		Yes		No		Are there any Tracking Systems installed:			Troughing		Return			
Is there any visible damage to structure caused by poor belt tracking:						Yes			No					
Conveyor belt length:						Are the tracking systems correctly positioned:			Yes		No			
Are the tracking systems firmly mounted:				Yes		No		Are all bolts & nuts tightened:			Yes		No	
Are all Idlers in contact with the Belt - Adequate Tension on the system:						Yes		No		Housekeeping:				
Comments:														

LOADING / TRANSFER CHUTE

Chute Condition:		Poor		Fair		Good		Material loading in centre of conveyor belt:						
Dead Boxes:		Yes		No		Deflector Plates:			Yes		No		Drop Heights:	
Tail Pulley Condition		Good		Fair		Poor								
Comments:														

KEYSKIRTING®

Size of Keyskirt®:		1	2	3	4	Length of Keyskirt® Installed :								
Positioning of Keyskirt® :						Other Product used as Skirting			Yes		No		State	
Mounting Arrangement		Std.			Offset			Other						
All bolts & nuts securely fastened:				Yes		No		Housekeeping:						
Comments:														

FEEDBOOTS

Type of Feedboot installed:		Universal		Combination		Is the system correctly positioned:		Yes		No	
						(System to be positioned centrally to the load area.)					
Drop Height:						Is the system securely mounted:		Yes		No	
All Bolts & Nuts tightened:		Yes		No		Condition of Idlers:		Poor		Fair	
Lead in and lead out Idlers in place:		Yes		No		Condition of UHMW Liners:		Low		Medium	
Housekeeping:											
Comments:											

HI - IMPACT SYSTEM

Type of Hi - Impact system installed:											
Is the system correctly positioned:				Yes		No		Drop heights:			
System to be positioned centrally to the load area.											
Is the system securely mounted:				Yes		No		All bolts & nuts tightened:		Yes	
Are all Idlers in contact with the belt:				Yes		No		Idler condition:		Poor	
BTA Condition:				Poor		Fair		Are chains / D shackles in place & securely fastened:		Yes	
All Hardware in Good Condition:				Yes		No		Housekeeping:			
Comments:											

AIR CANNONS

Size of Air Cannon Installed:		5ltr		Quantity		10ltr		Quantity			
		25ltr		Quantity		50ltr		Quantity			
		100ltr		Quantity		200ltr		Quantity			
Is the Air Cannon securely fastened onto the structure:				Yes		No		Is an Air Lance installed:		Yes	
Size of the Air Lance:								Are the Air Cannons correctly positioned:		Yes	
Power supply:								Air supply:			
Operating system:		Single timer		PLC		Manual push button		Sequential			
All Bolts & Nuts securely tightened:				Yes		No		All components in good order:		Yes	
Distance between Air Cannon & Solenoid Valve:								Any Air Leaks in the Pipe Work:		No	
Is a Water Trap Installed:				Yes		No		Is a Lubricator installed:		Yes	
Distance from Air Cannon:								Distance from Air Cannon:			
Are the safety / warning signs in place and visible:				Yes		No		Housekeeping:			
Comments:											

TAIL PULLEY / PLOUGH

Type / Model of Plough Installed:											
Are Flat Return Idlers installed:		(In front)	Yes		No		(Behind)	Yes		No	
Any excessive belt movement:		Yes		No		Adequate space for material to fall off of conveyor belt:		Yes		No	
Is the Plough firmly mounted:		Yes		No		Is the Safety Chain firmly mounted and correctly adjusted:		Yes		No	
Is the Plough free moving:		Yes		No		Is the entire Blade / Nose Piece in contact with the conveyor belt:		Yes		No	
Housekeeping:											
Comments:											

Brelko Supervisor

Name: _____

Date: _____

Signature: _____

Customer

Name: _____

Date: _____

Signature: _____



DOC No	ISSUE No	REVISION	OCTOBER	PAGE
FS 023	04	04	2018	Page 3 of 3



SHIPPING WEIGHTS

E205-S (STANDARD MOUNT)

BELT WIDTH	750	900	1050	1200	1350	1500	1650	1800	2100	2400
SIZE RANGE	Size 3				Size 4					
Kg	28.1	37.2	38.0	38.9	63.1	63.9	69.7	70.5	73.2	75.1
Lb	61.9	82.0	83.8	85.8	139.1	140.8	153.6	155.4	161.3	165.5

E205-T (TORSION MOUNT)

BELT WIDTH	750	900	1050	1200	1350	1500	1650	1800	2100	2400
SIZE RANGE	Size 3				Size 4					
Kg	32.0	43.3	44.1	45.0	72.4	73.3	79.1	79.9	82.5	84.3
Lb	70.5	95.5	97.2	99.2	159.6	161.5	174.3	176.1	181.8	185.8

SHIPPING DIMENSIONS

E205-S (STANDARD MOUNT)

BELT WIDTH	750	900	1050	1200	1350	1500	1650	1800	2100	2400
SIZE RANGE	Size 3				Size 4					
mm	305 x 235 x 2007				305 x 235 x 2007					
in	12 x 9.3 x 79				12 x 9.3 x 79					

E205-T (TORSION MOUNT)

BELT WIDTH	750	900	1050	1200	1350	1500	1650	1800	2100	2400
SIZE RANGE	Size 3				Size 4					
mm	305 x 235 x 2007				305 x 235 x 2007					
in	12 x 9.3 x 79				12 x 9.3 x 79					

11. Trouble Shooting

Problem	Possible Cause	Possible Solution
Poor cleaning performance	Scraper under-tensioned	Adjust to correct pressure - refer installation instructions
	Scraper over-tensioned	Adjust to correct pressure - refer installation instruction
	Scraper installed in wrong location	Verify dimension - refer installation drawing
	Scraper blade worn or damaged	Replace scraper blade
Rapid Blade Wear	Tension on scraper too high/low	Adjust to correct tension - refer installation instruction
	Scraper not located correctly	Check scraper location for correct dimensions
	Blade attack angle incorrect	Check scraper location for correct dimensions
	Material too abrasive for blade	Option: switch to alternate scraper tip grade (contact Brelko for available options)
	Mechanical splice damaging blade	Repair, skive or replace splice
Centre wear on blade (smile effect)	Blade smaller than material path	Add additional blade to match material path
	Tension on scraper too high/low	Adjust to correct pressure - refer installation instruction
Unusual wear or damage to blade	Mechanical splice damaging blade	Repair, skive or replace splice
	Belt damaged or ripped	Repair or replace belt
	Scraper not correctly located	Verify dimension - refer installation drawing
	Damage to pulley or pulley lagging	Repair or replace pulley
Vibration or noise	Scraper not located correctly	Verify dimension - refer installation drawing
	Blade attack angle incorrect	Verify dimension - refer installation drawing
	Scraper running on empty belt	Use a spray pole when the belt is empty
	Scraper tension too high/low	Adjust to correct pressure or slight adjust to diminish
	Scraper locking bolts not secure	Check and tighten all bolts and nuts
	Scraper not square to head pulley	Verify dimension - refer installation drawing
	Material build-up in chute	Clean up build-up on scraper and in chute
Scraper being pushed away from pulley	Scraper tension not set correctly	Ensure correct pressure/increase tension slightly
	Sticky material is overburdening scraper	Increase pressure; add primary (head pulley) scraper
	Scraper not set up correctly	Confirm location dimensions are equal on both sides